



Insulated Structures

Efficiency At Work

UPRIGHT SHADOW – WINE DISPLAY



Standard Specifications

• Internal Case Color Matt Black	• 2 x Probes (Air on & Defrost)
• Traffic Black Kick Plate	• ECM Fans
• 5 or 6 x Lit Shelves	• High Performance Coil
• Lighting: Vista 4000K 24V	• Electronic Temperature Display
• Flat Bottom Pan	• 40mm Lofty Glass Patch Ends
• Thermostatic Expansion Valves (Brass)	

Remote or Self-Contained

Leaders in world class innovation for bespoke end to end energy efficient refrigeration solutions



Insulated Structures
Efficiency At Work



Insulated Structures

Efficiency At Work

LOFTY SHADOW WINE DISPLAY

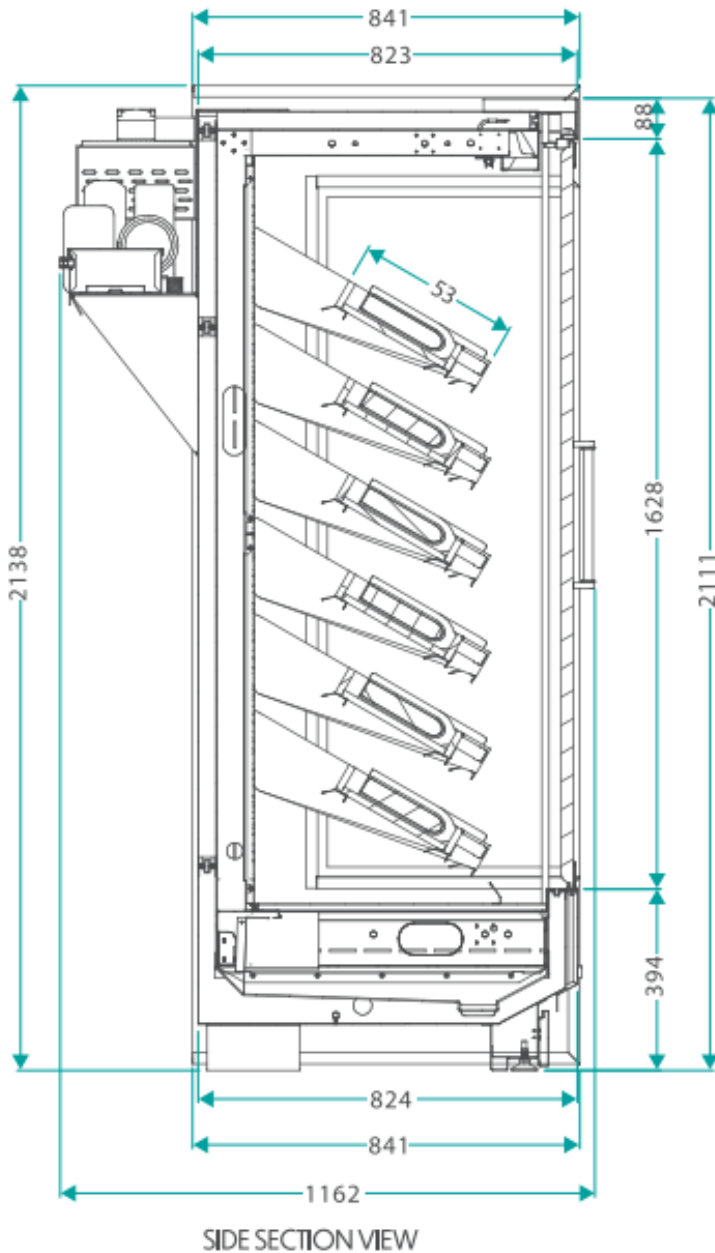

4ft, 6ft, 8ft & 12ft

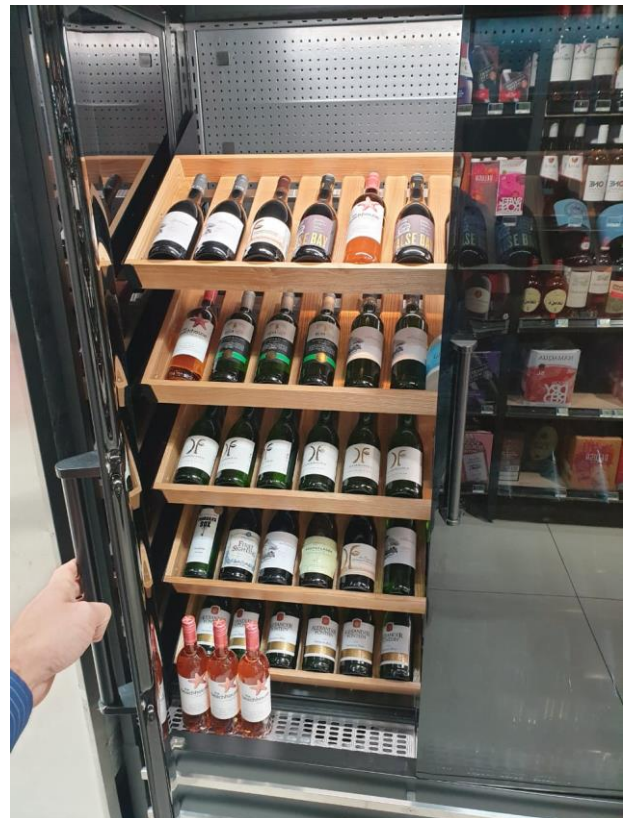

Leaders in world class innovation for bespoke end to end energy efficient refrigeration solutions



Insulated Structures
Efficiency At Work